

Design Considerations for a Universal Smart Energy Module for Energy Harvesting in Wireless Sensor Networks

Juergen Jessen, Marcus Venzke, and Volker Turau
Institute of Telematics, Hamburg University of Technology, Germany
Email: {juergen.jessen, venzke, turau}@tu-harburg.de
<http://www.ti5.tu-harburg.de>

Abstract—This paper presents the design of a universal energy module for nodes in wireless sensor networks. It supports a wide range of energy harvesters and energy storage systems. The focus is on the efficient conversion and storage of energy and to provide a smart platform for higher level energy management functions. The module provides maximum power point tracking and supports hybrid harvesters.

I. INTRODUCTION

Continuous power supply is a common problem for nodes in wireless sensor networks. Low-power components and power saving techniques like sleep-state duty cycling extend battery's lifetime significantly, but cannot prevent the inevitable starvation. The usefulness of further decreasing duty cycle diminishes, increasing lifetime no longer linearly, because self-discharge and sleeping currents gain significance. Considering typical battery capacities and the energy demand for wireless sensor nodes, the lifetime is limited to a few years at most.

Energy harvesting is a suitable solution for a potentially unlimited lifetime of wireless sensor nodes. Energy harvesters gather electric energy from different environmental energy sources, which though are rarely steady. A good example is sunlight, where radiation depends on daytime, season and weather. Therefore the energy needs to be buffered for periods of no harvested energy and for current peaks, which occur from typical node duty cycling.

In practice an unlimited lifetime is impossible because of aging effects of the components. Especially harvester and rechargeable energy buffers degrade and can supply and store less energy over the years. The choice of the components is a trade-off between functionality, price, volume, and lifetime. The efficiency of the power module is the greatest challenge, requiring carefully matched components, often limiting the choice of harvester and energy storage for the developer and limiting a system to unchanging environmental conditions.

This paper presents the design for a universal energy module, which supports different types of energy harvesters and storages. The module allows a second harvester connected at the same time (hybrid harvester) to increase the systems reliability. A single harvester like photovoltaic module can produce energy very unreliable for extended periods (as in winter). A complementary harvester, like a wind turbine, can mitigate this issue. The energy is stored in a multi-staged

energy storage, which is designed to minimize aging effects and improve reliability. To increase the power from the harvester, maximum power point tracking (MPPT) is employed. The MPPT is capable of real tracking, even allowing to find the global MPP. Together with an efficient output power supply, the module allows the energy efficient operation of the connected node. Besides proper and fault-proof operation the circuit also provides data about the module's state, which can be used for energy management on higher software levels. This universality comes at the cost of a higher system complexity and in most cases lower system-efficiency compared to specially designed fixed size and type harvester energy modules. Handling this complexity, discussing the problems, and giving possible solutions are the topics of this paper. The results are currently validated in a prototype implementation.

II. RELATED WORK

Energy harvesters are used in several projects. Especially photovoltaic modules are common, because they are cheap, easy to use, and efficient. One approach is presented in Enviromote [1]. Their goal is a cheap and easy circuit design for harvesting solar energy and storing it in a rechargeable NiMH accumulator. The concept of a multi-stage energy storage is shown in the Prometheus project [2]. A supercap is used as a primary buffer, while a rechargeable lithium-ion battery prolongs the node lifetime for extended periods of little or no sunshine.

In order to maximize the efficiency of energy harvesting, low power consumption of the components is necessary. The second influence factor is the efficiency of voltage conversion between the harvester, the energy storage, and the wireless sensor node. A few design considerations for sub-mW light energy harvesting systems are given in [3]. A more efficient circuit using only analog components for a thermoelectric energy harvester was developed by the Fraunhofer IIS and includes a minimized version of maximum power point tracking [4]. This approach is broadened to more harvesters in [5]. The focus is on self-powering and a maximized power output even for sub-mW harvesters.

A global viewpoint on energy efficiency is given in [6], considering aspects ranging from hardware to application and network protocols. The key issues and trade-offs which arise in

the design of a solar energy harvesting node are shown in [7], implemented in the prototype platform Heliomote. A complete MPPT system was implemented for the Everlast platform [8]. Here the solar energy is stored in a supercap only, which allows very long operation times of up to 20 years, but has little reserves for extended periods of no sunshine. A platform for dual harvesting solar and wind power employing MPPT is presented by Park et al. in AmbiMax [9]. The platform uses purely analog circuitry to improve efficiency.

The mentioned systems mainly focus on a single harvester, which is limited to solar energy in most cases. A universal approach is not intended, rather the optimization for a specific task. A universal energy module supports more types of harvesters and even hybrid harvesters with a single module and combines the advantages of the systems mentioned. It should automatically adapt to a wide range of harvesters and energy storages, using efficient energy conversion and MPPT to increase the power. Although based on analog circuitry for improved efficiency, additional digital support allows more universal reconfiguration without exchange of hardware components. This concept allows more complex monitoring and control, and the ability for executing high-level energy management functions. An early stage of this work led to the development of a simple photovoltaic energy module for the IRIS platform. The monitoring capabilities of the module were used to validate energy management functions like lifetime-prediction [10] and self-calibration [11].

III. REQUIREMENTS

The trend for nodes in wireless sensor networks is minimization, resulting not only in the smaller size of the components, but also a smaller battery volume and capacity. The battery must not drain empty and must support a reliable and maintenance-free operation during the prospected lifetime. Energy harvesters are used to recharge an energy storage, but the efficiencies of both are temperature dependent. Wireless sensor nodes are often operated outdoors, where temperatures of $-20^{\circ}C$ are not unlikely in winter. On the other side, in a closed box temperatures of more than $60^{\circ}C$ are possible at direct sunlight. However a limited functionality for the energy module and node may be admissible at extreme temperatures, allowing a decreased lifetime or a short blackout. Instead of building a complex and expensive fail-proof system, it is more important that the system can recover from blackout.

Wireless sensor nodes require a stable input voltage, typically in the range of 1.8-3.3 V for today's technologies. The average current is usually very low. While sleeping, it ranges in the magnitude of μA . From duty cycling operation long sleep periods are interrupted by short active phases with currents of several mA. The greatest challenge is a high efficiency for storing and providing energy, but at the same time not wasting it for its own operation.

A. Energy Harvester

While photovoltaic modules are the most common harvester type, other harvesters types should be supported as well. Due

	Photo-electric	Thermo-electric	Piezo-electric	Electro-static	Electro-magnetic	RF
Polarity	DC	DC (invertible)	AC	AC	AC	AC
Voltage	⊕⊕ 0.5 V ... 5 V	⊖ 10 mV ... 10 V	⊕ 10 V ... 100 V	⊕ 1 V ... 10 V	⊕ 0.5 V ... 5 V	⊖ 10 mV ... 5 V
Power	⊕⊕ 10 μ W ... 100 mW	○ 0.5 mW ... 10 mW	⊖ 1 μ W ... 10 mW	⊖ 10 μ W ... 10 mW	⊕⊕ 10 μ W ... 100 mW	⊖⊖ 0.1 μ W ... 1 mW
Impedance	1 k Ω ... 100 k Ω	1 Ω ... 10 k Ω	10 k Ω ... 100 k Ω	10 k Ω ... 100 k Ω	1 k Ω ... 10 k Ω	1 k Ω ... 10 k Ω
Challenge	impedance light dependent, inductor much less power	usually only small thermal gradient, efficient heat sink necessary	harvester frequency range fixed, phase shift of current & voltage	variable frequency, phase shift of current & voltage	infrequent short pulses with high energy from some harvesters	high frequency, low power at long distance

Table I
TYPICAL CHARACTERISTICS OF ENERGY HARVESTER TYPES

to size restrictions small energy harvesters are used, usually harvesting less than 1 mW. Requirements for an energy module can be derived by comparing and classifying harvester type characteristics. An overview of the most important characteristics is shown in Table I. Typical low power harvesters provide voltages from a few mV to several V and currents of up to 100 mA. The ranges of voltage and power in Table I are those of available and WSN suitable harvesters. The given rating marks the harvesting efficiency and usability of this energy. Harvester elements are often cascaded in parallel or serial for specific environmental conditions, to maximize power, and to keep current and voltage in a usable range. The harvester's range depends on its type and size and - more important - the environmental conditions, causing a high variability in its harvested current or voltage. The characteristic of this power-curve is influenced by the changing impedance of the harvester. Most energy can be harvested, when the impedance of the harvester and the consumer are matched. This optimal working point, the maximum power point, where harvestable power is maximized, is changing depending on the environmental conditions. A photovoltaic module is the most well known example for a characteristic voltage-current dependency with a distinct global maximum in power.

Many harvesters do not produce direct current (DC) but alternating current (AC), e.g. piezoelectric or electromagnetic harvesters. The current must be rectified and filtered. Though most harvesters produce a synchronous AC, the frequency however can differ by several orders of magnitude, depending on the environmental energy source, making it difficult to create a universal energy module. Another challenge is the phase-shift of current and voltage occurring in some harvesters, e.g. piezoelectric harvesters. To counter the effect of a parasitic capacitance in the harvester, an actively controlled inductance in parallel is required.

B. Energy Storage System

An energy storage for wireless sensor nodes needs to reliably provide energy in the entire temperature range, a long lifetime durability, a small size, and a small price. The small size is achieved by energy storages with a high energy density,

	EDLC	RAM	LSD-NiMH	Li-Ion	LiFe-PO ₄	Thin Film
Nominal Voltage	2,7 V	1,5 V	1,2 V	3,7 V	3,3 V	3,9 V
Typical Capacity	50 F	1800 mAh	2000 mAh	2400 mAh	1100 mAh	1 mAh
Typical Size	∅18x40 mm	∅14x50 mm	∅14x51 mm	∅18x65 mm	∅18x65 mm	25x25x0,17 mm
Energy Density	4,4 Wh/l	250 Wh/l	290 Wh/l	500 Wh/l	220 Wh/l	45 Wh/l
Cycle Lifetime	> 100 000	50...500	< 1000	> 1000	> 1000	10 000
Self-Discharge	50%/month	<0,2%/month	10%/month	5%/month	5%/month	0,1%/month
Temperature	-40...60°C	-20...65°C	-10...40°C	0...40°C	-30...60°C	-40...85°C

Table II
OVERVIEW RECHARGEABLE ENERGY STORAGE TECHNOLOGIES

while the durability is influenced by the number of recharge-cycles and the temperature-dependent degradation effects.

Characteristics of promising energy storage technologies are shown in Table II. The voltage of all technologies is sufficient to supply a wireless sensor node. Rechargeable alkaline manganese batteries (RAM) [12] and low self-discharge nickel-metal hydride batteries (LSD-NiMH) [13], [14] can easily be cascaded to increase the voltage. More important is the range of the voltage, which can differ significantly depending on the charging state, the discharge current, and the temperature. The electric double-layer capacitors (EDLC, supercap) [15] is a special case, because it behaves like a capacitor with voltages ranging from its nominal voltage down to 0 V. While most technologies are cheap for the available typical capacities given in Table II, supercaps and thin film solid electrolyte lithium batteries (Thin Film [16]) are comparatively expensive.

To ensure a reliable and efficient long-time operation, the durability is important. One factor is the number of charge-discharge cycles, before the capacity is dropping and impedance is rising to an unacceptable value. The time dependent aging effects are more difficult to compare, because they depend on the history of temperature and charging. For example RAM cells excel in durability, if the cycles are flat and the battery is kept near maximum capacity, while other technologies like lithium-ion batteries (Li-Ion) [17], [14] age faster, if the storage is empty or full. Generally the chemical batteries perform worse than the solid state thin film batteries or the supercaps. At lower temperatures all accumulator technologies except supercaps can only supply very low currents, sometimes not being rechargeable at all below 0°C (e.g. Li-Ion) [14].

Charging always involves thermal losses. For supercaps the efficiency for storing energy is nearly 100%. Li-Ion based technology still offers a high charge-discharge total energy efficiency of 90%, while for example NiMH offers only 70%.

Another important aspect lowering the efficiency of the system is the self-discharge, which is again dependent on temperature. The RAM cell, the three lithium based technologies, and the thin film batteries perform best. Energy loss from self-discharge scales with capacity, but also does the maximum current. This value is important for the node active-phase current peaks, especially at low temperatures. Thin film lithium batteries offer the best trade-off for the requirements mentioned in this paper. However because of the high price and low available capacities, only a few applications are realizable.

To benefit from the advantages of different technologies and minimize the disadvantages, it is useful to combine more

than one energy storage technology in a multi-stage design. A suitable design for a universal energy module consists of at least two stages, a short-time energy buffer and a long-time energy storage. To supplement the universal design and close the gap to classic WSNs, an optional non-rechargeable battery can be added, leading to a three-stage energy storage system. Depending on the specific application, the storage technologies and their capacities can be adapted and not all stages must be existent.

An **energy buffer** is used to store small amounts of energy to buffer the typical periodic power cycle of the harvester. To reduce wear of the other storage systems, whenever possible, the energy buffer stores the harvested energy and supplies the consumer. Supercaps are ideal as primary energy buffer. The advantages of supercaps are the nearly unlimited possible number of charge-discharge cycles with in addition high efficiency [15]. Supercaps can buffer high current peaks from duty-cycle operation. This is even possible at extreme conditions such as very low temperature. Though supercaps allow many charge-discharge cycles, they still age by time, especially at high temperatures, resulting in typical lifetimes of more than 10 years. Other disadvantages are a low energy density and a high self-discharge. To minimize size and self-discharge, the capacity needs to be small, storing more energy in the secondary energy storage stage.

A long-time **energy storage** can ensure proper operation for longer periods, if the harvested energy is not sufficient. A suitable energy storage is characterized by a high energy density and a low self-discharge. The storage is rechargeable, but recharges may degrade the energy storage and have less efficiency than the energy buffer. Therefore the use of the secondary stage should be minimized. Good examples are Li-Ion, low self-discharge NiMH accumulators, or second generation lithium accumulators like LiFe-PO₄. With dropping temperature they can supply orders of magnitude less current. The energy buffer or backup battery must mitigate this issue.

A non-rechargeable **backup battery** provides power, if energy buffer and energy storage are empty or fail. As a backup system the reliable operation is important. It requires a very high energy density and a very low self-discharge, combined with an extended operating temperature range. Lithium batteries are most suited for this purpose, providing higher energy densities than rechargeable technologies and a self-discharge of only 1% per year.

IV. UNIVERSAL ENERGY MODULE ARCHITECTURE

A universal energy module is the link between energy *harvester* and wireless sensor network *node*. A suitable architecture is presented in Fig. 1, showing the flow of energy through the module in layers from top to bottom. The module transparently provides the capability of storing and converting energy, independent of used harvester and node. Depending on the application, not all components must be existent. In Fig. 1 optional components are shown light colored.

The first layer, the *rectification*, is used to correct phase and polarity. The hybrid harvester concept combines two or more

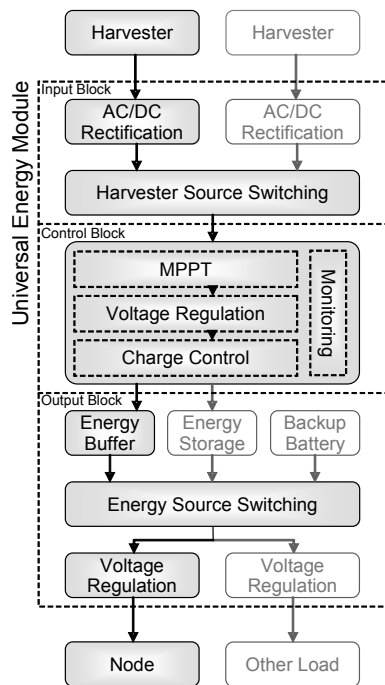

Figure 1. Universal Energy Module

types of harvesters. The harvesters can be used concurrently or a single harvester can be selected at a time. While the first idea aims at increasing the power output, the second concept aims at the improvement of the systems reliability by increasing the probability that the energy harvester can produce energy using different energy sources. Most likely impedance and voltage do not match. This would require two independent energy paths, multiplying the hardware effort for the circuit. This architecture follows the concept of switching between harvesters to improve the reliability of the system. In special cases a combination of the power from both harvesters can still be possible without additional hardware. The *rectification* circuit must be present twice anyway to resolve AC, frequency, and phase shift disparities for each channel. If the output voltages of the harvesters are similar, a superposition can be fed into the single *MPP tracking* stage. Although this may not allow operation at maximum power point for both harvesters, the superposed power can be higher than from one harvester alone. As the power can also be less, the originally described design acts as a fallback system.

The more complex control functions are combined in the middle control block. Using *MPP tracking* to maximize efficiency the harvested energy is used to charge the *energy storage*. *Voltage regulation* and *charge control* ensure correct charging of one *selected* energy storage.

Energy for the wireless sensor node is only supplied from one *selected* storage stage at the same time. Considering the mentioned advantages and disadvantages of the different energy storage stages in chapter III-B, usually the node should be supplied from the energy buffer, followed by the energy storage and only at last from the backup battery. The module powers the node at optimal voltage controlled by the *regulator*.

Additionally secondary software-adjustable voltage regulators may be useful to operate a sensor or actuator requiring a different voltage than the node.

V. ENERGY MODULE PLATFORM

An energy module is under development to meet the mentioned requirements and presented architecture. It is designed as stand-alone system and can therefore supply any typical wireless sensor node. The prototype energy module is built to support input voltages from harvesters of 0.7-5.5 V at a current range of 100 μ A-200 mA. These values have been selected to support a wide range of harvesters, but also limit the dimensioning of components to energy efficient smaller types. The module supports active AC/DC rectification and maximum power point tracking. For the energy storage system a supercap, a LiFe-PO₄, and a primary lithium battery have been selected.

The module uses a dedicated microcontroller on the energy module, because analog circuitry would be too complex to fulfill all tasks. To reduce power consumption a low-power microcontroller from the Atmel ATtiny family has been selected [18]. The microcontroller is clocked by a built-in RC-oscillator. An accurate clock frequency is not necessary, therefore the advantages of low power consumption and fast start-up of the RC-oscillator outbalance any other clock source. The clock frequency can be as low as 1 MHz, still allowing convenient communication speed with the wireless sensor node microcontroller. To further decrease the necessary energy, the microcontroller is operated in duty-cycle mode, sleeping most of the time. The microcontroller of the energy module is only powered from the harvester, not from the energy storage system. This eliminates power consumption, when no energy is harvested. The wireless sensor node may provide power, if the energy module's microcontroller has to be powered for energy management reasons.

Some functions are not controlled by the microcontroller, e.g. the AC/DC rectification circuit, parts of the MPPT, and the output energy storage selection. The use of analog circuits increases energy efficiency by enabling very low duty cycles. The microcontroller only needs to react on changing environmental conditions, allowing sleep periods in the scale of seconds. The power path and the control block of the universal energy module from Fig. 1 are shown in the system block diagram in Fig. 2. To simplify the architecture, only one harvester and energy storage are shown and the output voltage generation is left out.

A. AC/DC Rectification and Source Switching

For AC/DC rectification a full-wave bridge rectifier or a Delon or Greinacher circuit allowing to double the output voltage may be used. However, to further increase the efficiency of rectification, a synchronous active rectifier can be built by replacing the diodes of the full-wave bridge rectifier with MOSFETs. The necessary control circuit can be built from simple analog comparators comparing the input AC voltage levels and switching the correct path in the rectifier. To ensure

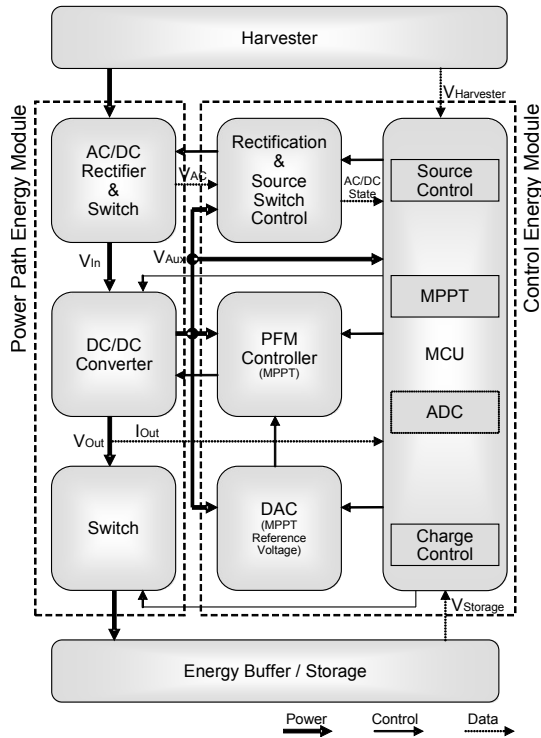

Figure 2. System Block Diagram Input Power Control

proper startup when no energy reserves are available, the rectification diodes remain in the system, but are bypassed by the MOSFETs for higher efficiency once the control circuit is running. The active rectifier is also useful for DC harvesters to prevent any current flow into the harvester, when it is not providing power. The actual implementation of switching is done in the AC/DC rectification stage. By overriding the rectification MOSFET control, the active rectification of a harvester is disabled. No separate stage in hardware is necessary, only some control logic. The passive rectification diodes can remain without problems.

B. Energy Monitoring and Management

The energy module periodically monitors the system-state. Primarily this data is needed for MPPT, charge-control, and energy management. Measurements are realized by the built-in analog-to-digital-converter (ADC) of the microcontroller. Time-critical controls like AC/DC rectification and parts of MPPT are done in dedicated hardware, therefore the intervals between measurements can be extended to reduce energy consumption. The following parameters are monitored (Fig. 2):

- Voltage of harvesters ($V_{Harvester}$, V_{In})
- AC/DC rectification controller state
- DC/DC converter (in Power Path) output current (I_{Out})
- Energy buffer, storage, and backup battery voltage
- Board temperature (μC on-chip sensor [18])

One functionality of energy management is providing monitored data to the microcontroller on the wireless sensor node. For communication SPI is used, also allowing reconfiguration of the energy module. For example the primary and secondary output voltage can be set or the energy storage parameters

reconfigured. The microcontroller on the energy board additionally acts as a platform for higher level energy management functions. The ability of controlling all external circuits, input and output currents allows numerous options such as estimation of remaining energy, prediction of remaining lifetime [10], or self-calibration of the capacity of connected energy buffers or storages [11].

The energy module is built to support different accumulator technologies. The charging algorithms are implemented in software and the parameters preconfigured in the microcontroller's internal EEPROM. The most important task while charging is monitoring the energy storage voltage. Depending on temperature and actual charge- or discharge-current the voltage can vary significantly, therefore charging is disabled and the power supply can be temporarily switched to another source to measure the open circuit voltage. The frequency of measurements can be low, because the energy storage capacity is high compared to the typical harvester output power. The maximum charging current for the energy storage is of minor importance, because the harvester's maximum current is usually lower. Nonetheless the charging current is anyways measured and could be controlled adjusting the MPPT control parameters (Section V-C), overriding the AC/DC rectification controls, or by duty cycling the energy storage switch.

The charging priority will be energy buffer before energy storage, but the software might choose a different strategy, depending on circumstances and used accumulator technology. Additionally the circuit must prevent a deep discharge, switching to other energy storages in due time. Another parameter influencing the charging strategy is temperature. For example, when temperature is below $0^{\circ}C$, the charging of Li-Ion storages must be stopped to prevent permanent damage (Section III-B). The accuracy of the ATtiny on-chip temperature sensor is only within $\pm 10^{\circ}C$ [18], but this will suffice for strategy decisions in charge control.

C. Maximum Power Point Tracking and Energy Conversion

Each harvester has an optimal operation point (MPP), where the harvested power is maximized (Section III-A). This point changes not only with harvester type, but with the amount of harvestable environmental energy, the temperature, and the wear of the harvester. This requires a continuous adjustment to track the MPP.

With a DC/DC converter between harvester and consumer, the operation point becomes adjustable by changing the duty cycle of the DC/DC converter. A boosting DC/DC converter furthermore allows the use of harvesters, whose output voltage is less than the energy storage voltage. Usually digital signal processors or microcontrollers are used to measure the necessary parameters and control MPPT at high frequency and accuracy. The disadvantage is the high energy consumption, which pays off only for harvesters of several Watt or better kW. In this design MPPT is done in analog circuitry supported by digital control. Usually environmental conditions do change very slowly. The microcontroller can sleep most of the time, adjusting parameters for the analog parts at low frequency.

The duty cycle of the DC/DC converter can be controlled by a pulse width modulation (PWM) or a pulse frequency modulation (PFM) signal. The low equivalent series resistance of energy storages like supercaps allows only short pulses from a PFM for charging, because otherwise the harvester voltage would drop too much. The system block diagram in Fig. 2 shows the control dependencies for MPPT. The PFM signal is generated from an analog comparator, which enables the DC/DC converter whenever the harvester voltage is higher than a reference voltage. Adding hysteresis stabilizes the comparator. The reference voltage is generated from the microcontroller using a digital-to-analog converter (DAC). The software will implement a Perturb and Observe strategy, slightly perturbing the harvester voltage periodically. Using the harvester power as weighting function, a hill climbing algorithm adjusts the voltage towards the MPP. Finally the operation point oscillates around the MPP.

If a hybrid harvester is connected, superposing two different current-voltage characteristics, local maxima can occur. The algorithms may get stuck in a local maximum. Solving this problem in analog circuitry is very difficult, but not using digital control. The microcontroller can configure the MPP to periodically sweep the whole range and measure the power to find the global maximum. Between these measurements the hill-climbing algorithm is used, requiring less energy.

The output voltage for the node should be set to the lowest possible voltage, because it influences the node's power consumption quadratically. The selected storage from the energy storage system rarely has the optimal voltage and it is varying with charge state, current, and temperature. Instead of a low-dropout regulator a DC/DC converter is usually more efficient. Optionally the voltage is adjustable by higher level energy management software. This would enable dynamic voltage scaling which can be used in combination with frequency scaling to decrease the energy consumption of the system. In the described design the output voltage is provided by the DC/DC converter TPS61220 from Texas Instruments.

D. Fail-Safe System

The safety features implemented in software as described in section V-B prevent hardware damage and ensure a stable system. Another aspect of fail-proof operation is the bootstrap capability of the energy module. Even if all energy storages are discharged, the system has to be able to recover. When the harvester can gather enough energy, the active AC/DC rectification is bypassed by the diodes (section V-A). This will power the DC/DC converter. At this time the energy storages are still disconnected, but the controller can start up. When the controller becomes active, it will enable active AC/DC rectification and MPPT to increase the efficiency of energy harvesting. At that point charging is started and when the energy buffer reaches a sufficient energy level, the consumer is activated. A self-powered control circuit for the output block ensures that energy for the wireless sensor node is only supplied from one storage stage at the same time.

VI. CONCLUSION AND NEXT STEPS

Many issues have to be considered to develop a universal energy module for wireless sensor nodes. They range from the efficient use of possibly different harvesters and the preservative application of suitable storage technologies to efficiency, fault-proofness, monitoring, and energy management topics. The presented energy module design solves these issues as a stand-alone system with a dedicated microcontroller.

Besides finalizing the prototype platform and taking efficiency measurements, future work involves improving the efficiency and implementing more parts in analog circuitry, lowering the operation power of the energy module. The energy management functionality is evolving, enabling autonomous self-calibrating modules and the migration of high level energy management functions from the wireless sensor node, allowing other developers to focus on wireless sensor network functionality rather than on energy problems.

REFERENCES

- [1] V. Kyriatzis et al., "Enviromote: A New Solar-Harvesting Platform Prototype for Wireless Sensor Networks / Work-in-Progress Report," in *Proc. of the Annual IEEE International Symposium on Personal, Indoor and Mobile Radio Communications (PIMRC '07)*, Athens, Greece, 2007.
- [2] X. Jiang, J. Polastre, and D. Culler, "Perpetual Environmentally Powered Sensor Networks," in *Proc. of the Intl. Symposium on Information Processing in Sensor Networks (IPSN '05)*, Los Angeles, USA, 2005.
- [3] W. W. et al., "Design considerations of sub-mw indoor light energy harvesting for wireless sensor systems," *ACM Journal on Emerging Technologies in Computing Systems*, vol. 6, no. 2, June 2010.
- [4] P. S. Loreto Mateu, Markus Pollak, "Analog Maximum Power Point Circuit Applied to Thermogenerators," *PowerMEMs*, 2008.
- [5] P. Spies, "Adaptive Power Management Circuits for Selfpowered Systems," in *Energy Harvesting and Storage Europe 2010*, Munich, Germany, May 2010.
- [6] V. Raghunathan, S. Ganeriwal, and M. Srivastava, "Emerging Techniques for Long Lived Wireless Sensor Networks," in *IEEE Communications Magazine*, Los Angeles, CA, USA, April 2006.
- [7] V. R. et al., "Design Considerations for Solar Energy Harvesting Wireless Embedded Systems," in *IPSN 2005*, LA, CA, USA, April 2005.
- [8] F. Simjee and P. H. Chou, "Everlast: Long-Life, Supercapacitor-Operated Wireless Sensor Node," in *Proc. of the Intl. Symposium on Low Power Electronics and Design (ISLPED '06)*, Tegernsee, Germany, 2006.
- [9] C. Park and P. H. Chou, "AmbiMax: Autonomous Energy Harvesting Platform for Multi-Supply Wireless Sensor Nodes," in *IEEE SECON*, Irvine, CA, USA, 2006.
- [10] C. Renner, J. Jessen, and V. Turau, "Lifetime Prediction for Supercapacitor-powered Wireless Sensor Nodes," in *Proc. of the 8th GI/ITG KuVS Fachgespräch "Drahtlose Sensornetze" (FGSN'09)*, August 2009, pp. 55–58.
- [11] C. Renner and V. Turau, "CapLibrate: Self-Calibration of an Energy Harvesting Power Supply with Supercapacitors," in *Proc. of the GI/ITG Workshop on Energy-aware Systems and Methods*, February 2010.
- [12] AccuCell, *Datasheet AccuCell*, May 2006. [Online]. Available: <http://www.accucell.de/pdf/AC1800DataSheet.pdf>
- [13] SANJO Electric CO Ltd, "Sanjo enloop rechargeable battery," <http://www.enloop.info/home/the-new-improved-enloop.html>, 2009.
- [14] I. Buchmann, "Battery university," <http://www.batteryuniversity.com>, 2005.
- [15] SAMWHA Electric, *Datasheet Green-Cap EDLC*. [Online]. Available: <http://www.samwha.com/electric/>
- [16] Infinite Power Solutions, *Datasheet THINERGY MEC*, http://www.infinitepowersolutions.com/images/pdfs/THINERGY_MEC101_DataSheet_v3-3_FEB2010.pdf, February 2010.
- [17] Shenzhen TrustFire Technology, "Trustfire rechargeable battery," http://trustfire.en.alibaba.com/productgroup/200513194/Rechargeable_Battery.html, 2010.
- [18] Atmel, *Datasheet ATtiny48/88*, June 2010. [Online]. Available: http://www.atmel.com/dyn/resources/prod_documents/doc8008.pdf